

---

**BERTAZZONI**  
**OWNER'S MANUAL**

---

**FREESTANDING FULL GAS RANGES**



## From the desk of the President

Dear new owner of a Bertazzoni,

I want to thank youDear new owner of a Bertazzoni appliance.

I want to thank you for choosing one of our beautiful products for your home.

My family started manufacturing kitchen appliances in Italy in 1882, building a reputation for quality of engineering and passion for good food.

Today, our products stand out because of their unique blend of authentic Italian design and superior appliance technology. It is our mission to make products that function perfectly and bring joy to their owners.

By making beautiful products we respond to our customers' flair for good design. By making them versatile and easy-to-use, cooking with Bertazzoni becomes a real pleasure.

This manual will help you learn to use and care for your Bertazzoni appliance in the safest and most effective way, so that it can give you the highest satisfaction for years to come.

Enjoy!

Paolo Bertazzoni  
President

A handwritten signature in black ink that reads "Paolo Bertazzoni". The signature is written in a cursive, flowing style with a prominent vertical stroke at the beginning.

---

**TABLE OF CONTENTS**

<b>WARNINGS</b>	<b>4</b>
<b>WORKTOP AND KNOBS LAYOUT</b>	<b>8</b>
<b>GAS COOKTOP</b>	<b>9</b>
Burners caps and grates	9
Making sure the flame is optimal	9
Using the gas burners	9
Using the power burner	10
Gas shut-off safety - thermocouple	10
Using specialty cookware	10
Gas burner dimensions and recommended pan size	10
<b>GAS OVEN</b>	<b>11</b>
Shelves positions	11
Cooling fan	11
Gas shut-off safety - thermocouple	11
Preheating the oven	11
Oven cooking modes	11
Special functions	12
Condensation	12
Getting the best results	13
Cooking recommendations	13
Broil recommendation	14
Troubleshooting common problems with oven cooking	14
Telescopic glides	15
<b>KEEPING YOUR BERTAZZONI CLEAN</b>	<b>16</b>
<b>SIMPLE MAINTENANCE</b>	<b>17</b>
Replacing oven lights	17
Cleaning inside glass door	18
<b>TROUBLESHOOTING</b>	<b>19</b>
<b>TWO YEAR LIMITED WARRANTY</b>	<b>20</b>

## WARNINGS

Warning and Important Safety Instructions appearing in this manual are not meant to cover all possible conditions and situations that may occur. Common sense, caution, and care must be exercised when installing, maintaining, or operating the appliance.

**Read and follow all instructions before using this appliance to prevent the potential risk of fire, electric shock, personal injury or damage to the appliance as a result of improper usage of the appliance. Use appliance only for its intended purpose as described in this manual.**

Save this Manual for local electrical inspector's use. Read and save these instructions for future reference. Observe all governing codes, ordinances and regulations.

### **WARNING!**

If the information in these instructions is not followed exactly, a fire or explosion may result causing property damage, personal injury or death.

- Do not store or use gasoline or other flammable vapors and liquid in the vicinity of this or any other appliance.

#### - WHAT TO DO IF YOU SMELL GAS

- Do not try to light any appliance.
- Do not touch any electrical switch.
- Do not use any phone in your building.
- Immediately call your gas supplier from a neighbor's phone. Follow the gas supplier's instructions.
- If you cannot reach your gas suppliers, call the fire department.

- Installation and service must be performed by a qualified installer, service agency or the gas supplier

### **In Massachusetts:**

All gas products must be installed by a "Massachusetts" licensed plumber or gasfitter. A "T" handle type manual gas valve must be installed in the gas line connected to this appliance.

To ensure proper and safe operation: Appliance must be properly installed and grounded by a qualified technician. DO NOT attempt to adjust, repair, service, or replace any part of your appliance unless it is specifically recommended in this manual. All other servicing should be referred to a qualified servicer. Have the installer show you the location of the gas shut-off valve and how to shut

it off in an emergency.

A certified technician is required for any adjustments or conversions to Natural or LP gas.

### **To Prevent Fire or Smoke Damage**

- Be sure all packing materials are removed from the appliance before operating it.
- Never let clothing, potholders, or other flammable materials come in contact with or too close to any element, top burner or burner grate until it has cooled.
- If appliance is installed near a window, proper precautions should be taken to prevent curtains from blowing over burners.
- Never leave any items on the cooktop. The hot air from the vent may ignite flammable items and may increase pressure in closed containers which may cause them to burst.
- Many aerosol-type spray cans are EXPLOSIVE when exposed to heat and may be highly flammable. Avoid their use or storage near an appliance.

### **In Case of Fire**

Turn off appliance and ventilation hood to avoid spreading the flame. Extinguish flame then turn on hood to remove smoke and odor.

- Cooktop: Smother fire or flame in a pan with a lid or cookie sheet.
- NEVER pick up or move a flaming pan.
- Oven: Smother fire or flame by closing the oven door. DO NOT use water on grease fires. Use baking soda, a dry chemical or foamtype extinguisher to smother fire or flame, if available, a multipurpose dry chemical or foam type extinguisher.

### **Child Safety**

- NEVER leave children alone or unsupervised near the appliance when it is in use or is still hot.
- NEVER allow children to sit or stand on any part of the appliance as they could be injured or burned.
- CAUTION do not store items of interest to children in cabinets above the range or on the backguard of the range. Children climbing on the range to reach those items could be seriously injured.

## Cooking Safety

- Once the unit has been installed as outlined in the Installation Instructions, it is important that the fresh air supply is not obstructed. The use of a gas cooking appliance results in the production of heat and moisture in the room in which it is installed.
- Ensure that the kitchen is well-ventilated. Keep natural venting holes open or install a mechanical ventilation device. Prolonged or intensive use of the appliance may call for additional (such as opening a window) or more effective ventilation (such as increasing the level of a mechanical ventilation if present).
- NEVER use aluminum foil to cover oven racks or oven bottom. This could result in risk of electric shock, fire, or damage to the appliance. Use foil only as directed in this guide.
- To eliminate the hazard of reaching over hot surface burners, cabinet storage should not be provided directly above a unit. Temperatures may be unsafe for some items, such as volatile liquids, cleaners or aerosol sprays.
- ALWAYS place a pan on a surface burner before turning it on. Be sure you know which knob controls which surface burner. Make sure the correct burner is turned on and that the burner has ignited. When cooking is completed, turn burner off before removing pan to prevent exposure to burner flame.
- ALWAYS adjust surface burner flame so that it does not extend beyond the bottom edge of the pan. An excessive flame is hazardous, wastes energy and may damage the appliance, pan or cabinets above the appliance. This is based on safety considerations.
- NEVER leave a surface cooking operation unattended especially when using a high heat setting or when deep fat frying. Boilovers cause smoking and greasy spillovers may ignite. Clean up greasy spills as soon as possible. DO NOT use high heat for extended cooking operations.
- DO NOT heat unopened food containers, build up of pressure may cause the container to explode and result in injury.
- ALWAYS let quantities of hot fat used for deep fat frying cool before attempting to move or handle.
- NEVER wear garments made of flammable material or loose fitting or long-sleeved apparel while cooking. Clothing may ignite or catch utensil handles. DO NOT drape towels or materials on oven door handles. These items could ignite and cause burns.
- ALWAYS place oven racks in the desired posi-

tions while oven is cool. Slide oven rack out to add or remove food, using dry, sturdy potholders.

- ALWAYS avoid reaching into the oven to add or remove food. If a rack must be moved while hot, use a dry pot-holder.
- ALWAYS turn the oven off at the end of cooking.
- Use care when opening the oven door. Let hot air or steam escape before moving or replacing food.
- DO NOT cook directly on the oven bottom. This could result in damage to your appliance. Always use the oven racks when cooking in the oven.

Do not connect any appliances to the plugs above or near to the induction cooktop; connection cable insulation can melt if in contact with heat, and this may result in an injury and a property damage.

## Recommended Utensils

- Use pans with flat bottoms and handles that are easily grasped and stay cool. Avoid using unstable, warped, easily tipped or loose-handled pans. Also avoid using pans, especially small pans, with heavy handles as they could be unstable and easily tip. Pans that are heavy to move when filled with food may also be hazardous.
- Be sure utensil is large enough to properly contain food and avoid boilovers. Pan size is particularly important in deep fat frying. Be sure pan will accommodate the volume of food that is to be added as well as the bubble action of fat.
- To minimize burns, ignition of flammable materials and spillage due to unintentional contact with the utensil, DO NOT extend handles over adjacent surface burners. ALWAYS turn pan handles toward the side or back of the appliance, not out into the room where they are easily hit or reached by small children.
- NEVER let a pan boil dry as this could damage the utensil and the appliance.
- Follow the manufacturer's directions when using oven cooking bags.
- Only certain types of glass, glass/ceramic, ceramic or glazed utensils are suitable for range-top surface or oven usage without breaking due to the sudden change in temperature. Follow manufacturer's instructions when using glass.

## Induction Cooking Surfaces

- Surface areas on or adjacent to the unit may be hot enough to cause burns. Do not touch the cooking area as long as the light indicating residual heat on the glass-ceramic cooktop area, is “on”; this indicates that the temperature in the relative area is still high.
- DO NOT COOK ON BROKEN COOKING SURFACE – If cooking surface should break, cleaning solutions and spillovers may penetrate the broken cooking surface and create a risk of electric shock. Contact a qualified technician immediately.
- Keep a close eye on children because they are unlikely to see the residual heat warning lights. The cooking zones are still very hot for some time after use, even if they are switched off. Make sure that children never touch them.
- NEVER use aluminum foil to hold the food while cooking on a glass-ceramic cooktop area.
- Never place pan with bottoms which are not perfectly flat and smooth on the cooktop area.
- If you drop a heavy pot on your cooktop area it will not break. On the contrary, if a hard object, such as the salt shaker or the spice bottle strikes the edge or the corner of the cooktop area, the cooktop area may break.
- Never use the glass-ceramic cooktop area as support surface.
- Only use cleaning products made specifically for ceramic glass cooking surfaces.

Metal items such as cutlery or lids must never be placed on the surface of the cooktop area since they may become hot.

## Oven Heating Elements

- NEVER touch oven bake and broil burner areas or interior surfaces of oven.
- Bake and broil burners may be hot even though they are dark in color. Areas near burners and interior surfaces of an oven may become hot enough to cause burns.
- During and after use, DO NOT touch or let clothing or other flammable materials contact heating elements, areas near elements, or interior surfaces of oven until they have had sufficient time to cool. Other surfaces of the oven may become hot enough to cause burns, such as the oven vent opening, the surface near the vent opening, and the oven door window.

## Cleaning Safety

- Turn off all controls and wait for appliance parts to cool before touching or cleaning them. DO NOT touch the burner grates or surrounding areas until they have had sufficient time to cool.

- Clean the range with caution. Avoid steam burns; DO NOT use a wet sponge or cloth to clean the range while it is hot. Some cleaners produce noxious fumes if applied to a hot surface. Follow directions provided by the cleaner manufacturer.
- DO NOT clean, rub, damage, move or remove the door gasket. It is essential for a good seal during baking. If the gasket becomes worn or excessively soiled with food particles, replace gasket to assure a tight seal.

## Power failure warning

Due to safety considerations and the possibility of personal injury in attempting to light and extinguish the oven burners, the grill and the oven burner should not be used during a power failure. The oven control knob should always remain in the “OFF” position during a power failure.

## WARNING!

Never use this appliance as a space heater to heat or warm the room. Doing so may result in carbon monoxide poisoning and overheating of the oven

## Room ventilation

An exhaust fan may be used with the appliance; in each case it shall be installed in conformity with the appropriate national and local standards. Exhaust hood operation may affect other vented appliances; in each case it shall be installed in conformity with the appropriate national and local standards.

## Electrical shock hazard

Make sure all controls are OFF and oven is COOL before cleaning. Failure to do so can result in burns or electrical shock.

DO NOT touch a hot oven light bulb with a damp cloth as the bulb could break. Should the bulb break, disconnect power to the appliance before removing bulb to avoid electrical shock.

## WARNING!

Never cover any slots, holes or passages in the oven bottom or cover an entire rack with materials such as aluminum foil. Doing so blocks air flow through the oven and may cause carbon monoxide poisoning. Aluminum foil linings may also trap heat, causing a fire hazard.

## Burn hazard

The oven door, especially the glass, can get hot. DO NOT touch the oven door glass!

**Warning-tipping hazard**

A child or adult can tip over the range and be killed.

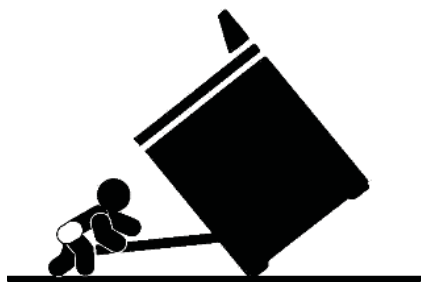

Verify the anti-tip device has been properly installed and engaged.

Ensure the anti-tip device is re-engaged when the range is moved.

Do not operate the range without the anti-tip device in place and engaged.

Failure to do so can result in death or serious burns to children or adults.

The instructions shall warn the user of possible hazard or injuries that may result from the misuse of appliance doors such as stepping, leaning or sitting on the doors.

**WARNING:**

Cancer and Reproductive Harm-  
[www.P65Warnings.ca.gov](http://www.P65Warnings.ca.gov).

## WORKTOP AND KNOBS LAYOUT

### Heating element

- |   |                         |
|---|-------------------------|
| 1 | Oven functions selector |
| 2 | Oven thermostat         |
| 3 | Left front burner       |
| 4 | Left rear burner        |
| 5 | Right front burner      |
| 6 | Right rear burner       |

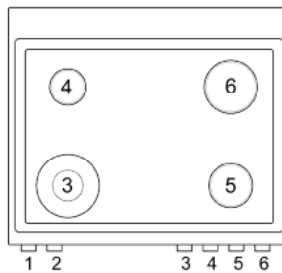



## GAS COOKTOP

### BURNER CAPS AND GRATES

The burners and the burner caps must be properly placed for the cooktop to function properly.

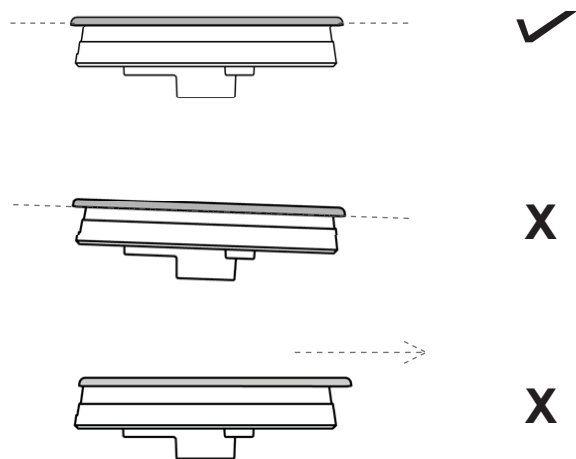

The burner grates must be properly placed inside the recess on the cooktop.

### MAKING SURE THE FLAME IS OPTIMAL

The flame should be stable with no excessive noise or fluttering. The color should be blue with no yellow on the tips. It is not uncommon to see orange in the flame color; this indicates the burning of airborne impurities in the gas and will disappear with use.

- With propane (LP) gas, slight yellow tips on the primary icon are normal.
- The flame should burn completely around the burner cap. If it doesn't, check that the cap is positioned correctly on the base and that the ports are not blocked.

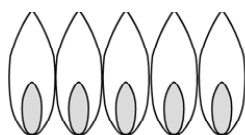

yellow flames:  
further adjustment is required

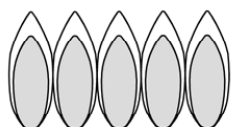

yellow tips on outer cones:  
normal for LP gas

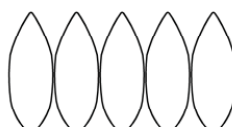

soft blue flames:  
normal for natural gas

The correct flame height depends on:

- size and material of pan being used
- food being cooked
- amount of liquid in the pan.

Never extend the flame beyond the base of the pan. Use a low or medium flame for pan materials that conduct the heat slowly, such as porcelain coated steel or glass-ceramic.

Because the edges of the flame are much hotter than its center, the flame tips should stay beneath the bottom of the cookware. Flame tips which extend beyond the sides of the cookware emit unnecessary heat into the room and can also damage cookware handles, which increases the risk of injury.

### USING THE GAS BURNERS

- Press in the control knob and turn it anti-clockwise, to HIGH position.
- Continue to hold the knob in for 5 to 10 seconds after the burner ignition before releasing
- Adjust flame with the knob as needed.

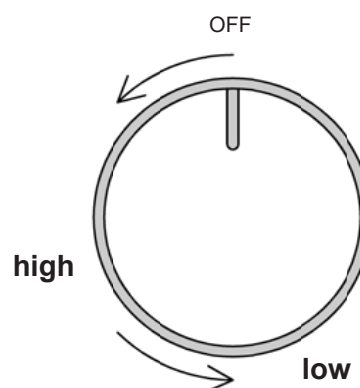

### USING THE POWER BURNER

To give further flexibility, the dual power burner can be used as a single simmer burner if the central burner alone is ignited or as a power burner if the outer burner is also ignited.

To light the central burner, press in the control knob and turn it anti-clockwise to the HIGH of the single ring position

Continue to hold the knob in for 5 to 10 seconds after the burner ignites before releasing

To also light the outer burner, turn the knob to the HIGH double ring. Adjust the flame as required.

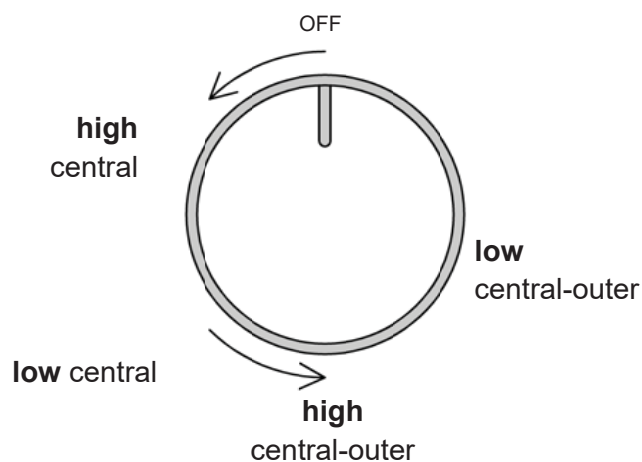

### GAS SHUT-OFF SAFETY - THERMOCOUPLE

A flame failure device (thermocouple) on each burner acts as a safety gas cut-off in case the flame is accidentally blown out. A thermocouple detects the absence of a flame and stops the supply of gas. The thermocouple must be heated for a few seconds when the burner is ignited before the knob is released.

### USING SPECIALTY COOKWARE

#### Woks

Either flat-based or round-bottom woks with the accessory ring can be used on all models. Round bottom woks must be used with a support ring. In some models the porcelain-coated cast iron wok support ring must be purchased separately.

#### Simmer ring

For very slow cooking the porcelain coated simmer ring should be used. In some models the porcelain-coated cast iron simmer ring must be purchased separately.

Simmer ring must be used for pan with diameter less than 4 inches.

**NOTE:** In the event of a power failure, the burners can be lit with a match or gas lighter. The flame failure devices will continue to function normally.

### GAS BURNER DIMENSIONS AND RECOMMENDED PAN SIZE

Burner	Diam. in (mm)	Diam. of pan	Utilization
Auxiliary	Ø 2" (50mm)	Ø 3"1/2- 5"1/2 (90-140mm)	Use with smaller pans for boiling and simmering and the preparation of sauces.
Semi-rapid	Ø 2"3/4 (70mm)	Ø 5"1/2 -10"1/4 (140-260mm)	Use for normal frying and boiling in medium and small pans.
Rapid	Ø 3"3/4 (95 mm)	Ø 7"1/8 -10"1/4 (180-260 mm)	Use with large and medium pans of water for frying and rapid boiling.
Dual inner/outer or Wok	Ø1"11/16-5"1/2 (43-140 mm)	Ø 8"2/3 -10"1/4 (220-260 mm)	Use with woks, griddle's and frying pans or for large pans and rapid boiling.

## GAS OVEN

### Warning!

Do not use the gas oven in case of electric power failure. In case of electric power failure reset oven/broiler controls to OFF position. Oven/broiler burners cannot operate until electric power is restored to the appliance.

If the oven burner flame is extinguished accidentally during operation, turn the temperature control knob counter-clockwise to the OFF position. Wait at least 60 seconds before attempting to light the oven again.

**ATTENTION!** When using the oven for the first time it should be operated for 15-30 minutes at a temperature of about 500°F/260°C without cooking anything inside in order to eliminate any moisture and odours from the internal insulation.

### SHELVES POSITIONS

Shelves are mounted on the appropriate guides situated on the sides of the oven compartment. Insert the shelf between top and bottom guide in any of the 5 positions indicated.

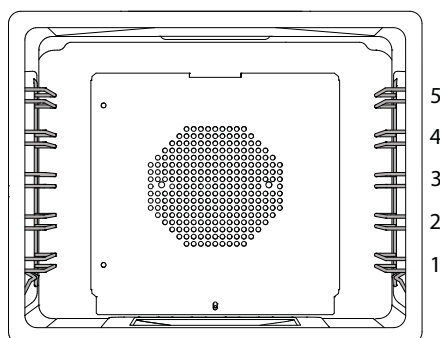

### COOLING FAN

Automatic operation of the cooling fan.

The range cooker is equipped with a thermostatically controlled cooling fan designed to prevent the control panel and knobs from overheating. The cooling fan will operate when the oven temperature rises. It will turn off when the temperature decreases.

**NOTE:** It is normal for the cooling process to push heated air out into the room when the oven is on.

### GAS SHUT-OFF SAFETY - THERMOCOUPLE

A flame failure device (thermocouple) on each burner acts as a safety gas cut-off in case the flame is accidentally blown out. A thermocouple detects the absence of a flame and stops the supply

of gas. The thermocouple must be heated for a few seconds when the burner is ignited before the knob is released.

### PREHEATING THE OVEN

Most cooking times in recipes are intended for a preheated oven and require that the oven already be at the set temperature before placing food in the oven. Preheating time depends on the temperature setting and the number of racks in the oven.

### OVEN COOKING MODES

The oven is equipped with several elements, used alone or in combination to create different cooking modes:

- Bake burner
- Broil burner
- Oven fan

*The temperature setting and cooking times can vary slightly from one oven to another. It is possible that recipes and cooking times need to be adjusted accordingly.*

### Bake

*Heat from bake burner only.*

Use this setting for baking, roasting, and casseroles.

- Open the oven door, with oven/broiler thermostat knob in the OFF position,
- Press the thermostat knob for about 1 to 2 sec., release it immediately
- Turn it to the desired oven temperature; if the burner does not light up, turn the thermostat knob to the OFF position again and wait 1 minute before repeating the sequence.
- The gas oven operation is indicated by the light in the cavity.
- Wait 20sec. before closing the oven door, visually check that the flame is on through the portholes on the oven compartment bottom panel. If no flame is visible, repeat the procedure.
- After lighting the burner and setting the desired temperature, wait until the thermometer shows the set temperature before placing food in the oven.

The BAKE mode is best for baking on one rack:

- Standard baking: level 2 or 3
- Baking tall items: level 2
- Pies: level 1 or 2
- Large cuts of meat or poultry: level 1

## **Convection bake**

*Heat from bake burner and airflow convection with fan.*

Cooking with convection has several advantages. In the convection system, two fans in the back of the oven move heated air evenly around the cavity, eliminating hot and cold spots and ensuring temperature is even. Multiple dishes can be cooked at the same time on different levels, without having to rotate the pans. For convection, use shallow bakeware to reduce heat shadows.

Food cooked uncovered will brown evenly and form a nice crust. Food placed in covered bakeware or delicate custards do not benefit from convection cooking.

Preheat the oven as for BAKE and turn the function knob to 'CONVECTION' before placing the food in the cavity.

- Single rack: use the same rack position as bake
- 2 racks: use level 2 and 4
- 3 racks : use level 1, 3, 5

## **Broil**

*Infrared heat from the BROIL burner in the top of the cavity.*

Use this setting for broiling/grilling dark meats 1" thick or less to rare or medium doneness.

Before turning on the oven, place the rack in the desired position. After preheating the broiler, center the broil pan under the broil element.

## **Preheating the Broiler**

It is recommended that you preheat the broil element before starting to cook. Preheat for 5 minutes then place food in oven.

- Open the oven door, with oven/broiler thermostat knob in the OFF position,
- press the thermostat knob for about 1 to 2 sec., release it immediately
- turn it to ' BROIL ' ; if the broiler fails to light up, turn the thermostat knob to the OFF position again and and wait 1 minute before repeating the sequence.
- The gas broil operation is indicated by the light in the cavity.
- Wait 20 sec. before closing the oven door, visually check that the flame is on.If no flame is visible, repeat the procedure.

The broil mode is effective when food is placed on upper racks.

- Beef steaks, ground meat patties, and lamb chops 1 inch or less: level 5.
- Meat 1 inches or more thick, fish, poultry, pork chops, ham steaks 1 inch or more: level 4.
- Browning food: level 5.

## **SPECIAL FUNCTIONS**

### **Light**

Use this function to light the oven when the oven is off (for example to clean the oven). Turn the function knob to 'bake'. DO NOT turn on Oven Temperature Control Knob.

### **Proofing**

The proof feature maintains the warm, needed for proofing yeast. It is best to start with a cool oven when using the proofing function. Turn the function knob to 'light'. DO NOT turn on Oven Temperature Control Knob. Do not open the oven door unnecessarily.

### **Convection defrost**

Air is circulated by the airflow fans. The fan accelerates natural defrosting of food without heat. DO NOT leave defrosted food in the oven for more than two hours. Place the frozen food on a baking sheet. Turn the function knob to 'CONV'. DO NOT turn on Oven Temperature Control Knob.

## **CONDENSATION**

It is normal for a certain amount of moisture to evaporate from the food during any cooking process. The amount depends on the moisture content of the food. The moisture will condense on any surface cooler than the inside of the oven, such as the control panel.

## **Using aluminum foil in the oven**

Foil can be used to cover food in the oven but this should not come into close proximity with the oven elements. Foil should not be used to line the oven cavity or grill pan. This can cause overheating, buckling and cracking of the enamel surfaces.

## GETTING THE BEST RESULTS

- Minimize opening and closing the oven door during operation.
- Use the rack position recommended by the recipe and fine-tune with personal experience.
- Use the bakeware recommended in the recipe.
- Store the broiler pan(s) outside the oven. An extra pan without food will impact browning and cooking.
- For tender, golden brown crusts, use light non-stick/anodized or shiny metal pans.
- For brown crisp crusts, use dark non-stick/anodized or dark, dull metal pans or glass bakeware. These may require lowering the bake temperature 25°F (14°C).
- Allow at least 1" (25.4 mm) of space between the pans and the oven walls so heat can circulate around each pan.
- To keep the oven as clean as possible, cook meat on a pan and not directly on the racks.

## COOKING RECOMMENDATIONS

Food	Pan size	Control temperature setting	Total suggested cooking time
Cookies	12"x15" Cookie Sheet	375°F	8 to 12 minutes
Layer Cakes	8" or 9" Round	350°F	25 to 35 minutes
Sheet Cakes	9"x13" Pan	350°F	30 to 40 minutes
Bunt Cakes	12 Cup	325°F	60 to 75 minutes
Brownies or Bar Cookies	9"x9" Pan	325°F	20 to 25 minutes
Biscuits	12"x15" Cookie Sheet	425°F or Package Directions	10 to 15 minutes
Quick Bread	8"x4" Loaf Pan	350°F	55 to 70 minutes
Muffins	12 cup Muffin Pan	425°F	14 to 19 minutes
Fruit Pies	9" Diameter	425°F	35 to 45 minutes
Fruit Cobblers	9"x9" Pan	400°F	25 to 30 minutes
Yeast Bread, Loaves	8"x4" Loaf Pan	375°F	25 to 30 minutes
Dinner Rolls	9"x13" Pan	400°F	12 to 18 minutes
Cinnamon Rolls	9"x13" Pan	375°F	25 to 30 minutes
Yeast Cotter and Cake	12"x15" Cookie Sheet	400°F	20 to 30 minutes

**BROIL RECOMMENDATION**

Food item	Control temperature setting selector	Approximate cooking time	Special instructions and tips
BEEF Ground Beef Patties, ½" thick	500°F fixed temperature setting	15 to 20 minutes	Broil until no pink in center
T-Bone Steak	500°F fixed temperature setting	12 to 20 minutes	Time depends on rareness of steak
Flank Steak	500°F fixed temperature setting	12 to 20 minutes	Rare to Medium Rare
Eye of Round Roast	325°F	20 to 25 min/lb	Small roasts take more minutes per pound; reduce time by using Convection Bake
PORK Loin Roast	325°F	20 to 25 min/lb	Cook until juices are clear
POULTRY Boneless Skinless Chicken Breasts	500°F fixed temperature setting	20 to 25 minutes	Cook until juices are clear
Chicken Thighs	500°F fixed temperature setting	25 to 30 minutes	Remove skin; Cook until juices are clear
Half Chickens	500°F fixed temperature setting	30 to 45 minutes	Turn with tongs; Cook until juices are clear
Roast Chicken	350°F	75 to 90 minutes	Do not stuff; reduce time by using Convection Bake
Turkey	325°F	20 to 25 min/lb	Do not stuff; reduce time by using Convection Bake

**TROUBLESHOOTING COMMON PROBLEMS WITH OVEN COOKING**

Problems	Cause	Remedy
Cakes burned on the sides or not done in center	Oven too hot Wrong pan size	Reduce temperature Use recommended pan size
Cakes crack on top	Batter too thick Oven too hot Wrong pan size	Follow recipe or add liquid Reduce temperature Use recommended pan size
Food too brown on bottom	Oven door opened too often Incorrect rack position Wrong bake setting	Use door window to check food Use recommended rack position Adjust to conventional or convection setting as needed
Food too brown on top	Incorrect rack position Oven not preheated	Use recommended rack position Allow oven to preheat
Cookies too flat	Hot cookie sheet	Allow sheet to cool between batches
Pies burned around edges	Oven too hot Oven not preheated	Reduce temperature Allow oven to preheat
Pies too light on top	Oven not hot enough Oven not preheated	Increase temperature Allow oven to preheat

## TELESCOPIC GLIDES (optional)

The telescopic glides fit any shelf level and work with the wire shelves provided as standard equipment.

### Fitting the glides

- 1 - Locate the two spring clips at the front and back of the glides.
- 2 - Locate the pin on the glide that indicates the back.
- 3 - Choose the right level and position the telescopic glide near the upper wire.
- 4 - Gently insert the front spring clip on the glide.
- 5 - Insert the rear spring clip on the glide.
- 6 - Pull and push each glide to ensure the correct installation and smooth operation.
- 7 - Extract both glides to the fully extended position and place the shelf over them, making sure it's accurately placed between the rear pin and the front pin.

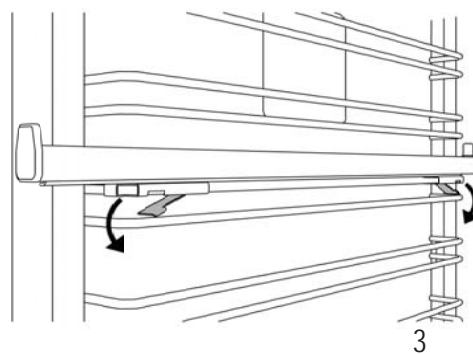
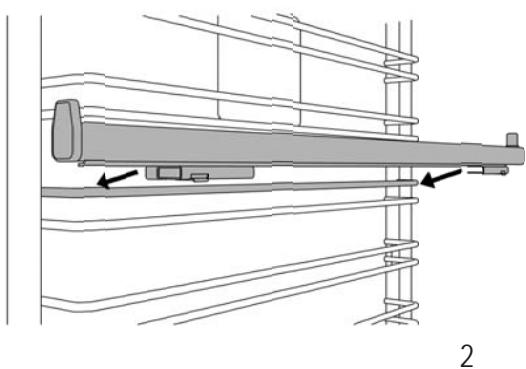
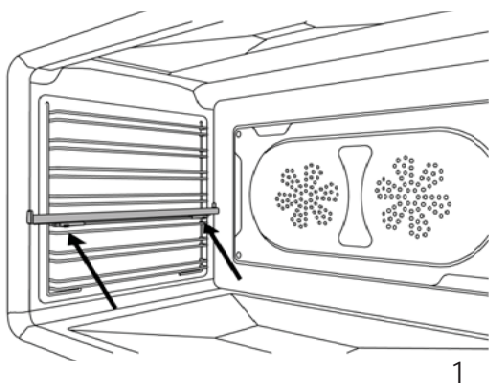

### Removing the glides

- 1 - Locate the two spring clips at the front and back of the glide.
- 2 - Gently pull down the front spring clip.
- 3 - Pull the glide away from the oven side - be careful not to strain the clip.
- 4 - Repeat steps 2 - 3 on rear spring clip to remove glide.

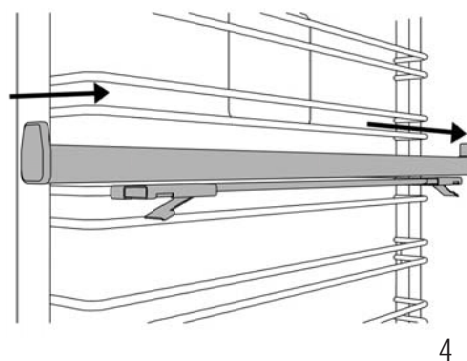

## KEEPING YOUR BERTAZZONI CLEAN

### Burn hazard

Make sure the heating elements are turned off and allowed to cool completely before any cleaning and/or maintenance operation.

### Things to avoid:

- Do not use a steam cleaner to clean the range: the steam could reach electrical components and cause a short.
- Do not spray liquids such as cleaning agents into the openings on the bottom and top of the oven cavity.
- All surfaces can discolor or be damaged if unsuitable cleaning agents are used. The front of the oven, in particular, will be damaged by oven cleaners and descalers. All surfaces are susceptible to scratching. Scratches on glass surfaces may cause a breakage. Immediately remove any residues by using suitable cleaning products.
- The heating elements in the oven do not require cleaning. The elements burn off any residue when the oven is in use.

### Cleaning stainless steel

All stainless steel parts should be wiped with hot water and soap solution at the end of each cycle. Wipe up spills and boilovers immediately. Use suitable, non-abrasive stainless cleaning products when water and soap solution will not do the job. *DO NOT use steel wool, abrasive cloths, cleaners, or powders.* If necessary, scrape stainless steel to remove encrusted materials, soak the area with hot towels to soften the residue, then use a wooden or nylon spatula or scraper. *DO NOT use a metal knife, spatula, or any other metal tool to scrape stainless steel.* DO NOT permit citrus or tomato juice to remain on stainless steel surface, as citric acid will permanently discolor stainless steel.

### Cleaning painted surfaces

Clean with a soft cloth, warm water and non-abrasive dishwashing liquid. Whilst still damp, polish dry with a clean soft cloth.

### Cleaning glass surfaces

Clean with cleaning detergent and warm water. Glass cleaner can be used to remove fingerprints. If using glass cleaner containing ammonia, make sure that it does not drip on exterior door surface.

### Cleaning the broiler pan

Clean with detergent and hot water. For stubborn spots, use a soap-filled steel wool pad.

The porcelain enamel finish is acid resistant, but not acid proof. Acidic foods, such as citrus juices, tomatoes, rhubarb, vinegar, alcohol or milk, should be wiped up and not allowed to bake onto the porcelain during the next use.

### Cleaning the stainless steel griddle

The stainless steel griddle is quite heavy and it can be cleaned in place without removing it. After cooking, allow the Griddle to cool until just warm. Use a spatula to remove any cooking residue. Wipe away any fat in the drip tray with paper towels. Clean the entire surface with warm water and dishwashing liquid, using a stainless steel scourer. Always work with the grain of the stainless steel. Certain types of food with high sodium content such as bacon may leave white marks. For these and other stubborn marks, use a cream cleaner suitable for stainless steel surfaces.

### Cleaning the oven cavity

- Always allow the oven interior to cool before cleaning.
- Do not allow vinegar, wine, coffee, milk, salt water or fruit juices to remain in contact with enamelled surfaces for prolonged periods as they may stain or discolour the surface.
- Never use sharp utensils to remove stains as this could scratch the surface.
- Never use steam cleaners on the oven interiors as steam may damage electronic parts.
- For light cleaning, wipe with a soft cloth, using warm water and washing up liquid. For heavier residues, use a cream cleaner and a nylon scourer.
- Oven cleaning products can be used according to the manufacturer's directions but care should be taken that they do not come in contact with any stainless steel, chrome, painted or alloy parts of the range or the door seals and elements.

### Cleaning oven racks and supports

Clean with detergent and hot water. Stubborn spots can be scoured with a soap-filled steel wool pad.



## SIMPLE MAINTENANCE

Keeping appliance area clear and free from combustible materials, gasoline and other flammable vapors or liquids.

Not obstructing the flow of combustion and ventilation air.

These simple tasks can be performed by the owner. For any other maintenance task, we recommend employing a trained service technician. Please call our toll free line to identify service technicians in your area:

### ENGLISH 866 905 0010

if located in the US, BC, B, Sk and MB

### FRANCAIS 800 561 7265

if located in ON, QC, PE, NU, NS, NL, NB

## REPLACING OVEN LIGHTS

### Warning! Electric shock hazard!

Disconnect the electric power at the main fuse or circuit breaker before replacing bulb. DO NOT touch bulb with bare hands. Clean off any signs of oil from the bulb and handle with a soft cloth.

### Top oven light

*Bulb type: halogen G9 120 V, 25 W*

- Make sure the heating elements are turned off and allowed to cool completely. Disconnect the appliance from the power supply.
- Unscrew the glass cover and remove the halogen bulb.
- Place a new halogen bulb in its slot. DO NOT touch bulb with bare hands
- Screw the glass cover back in place.
- Reconnect the oven to the electrical supply.

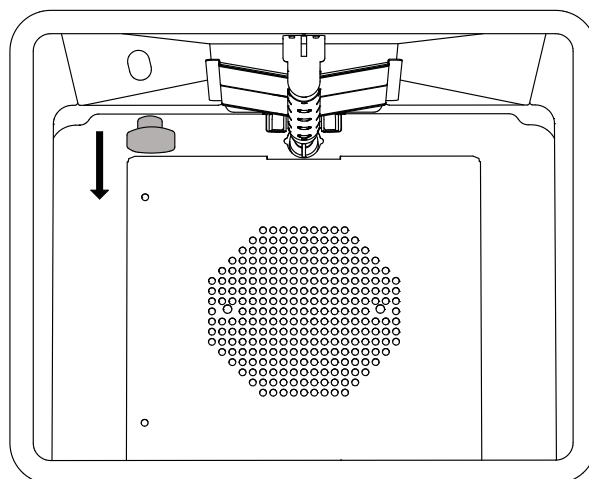
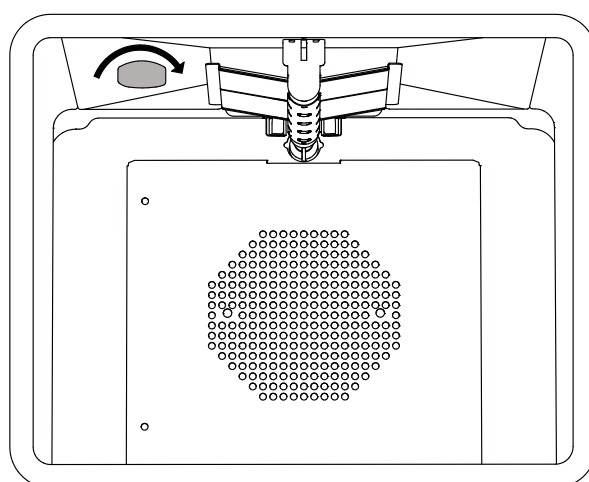

## CLEANING INSIDE GLASS DOOR

The inner glass door panels can be easily removed for cleaning. It is not necessary to remove the door in order to clean the glass panes. The glass can be cleaned in situ or removed.

- Open the oven door to its fully extended position.
- Insert the pin into each hinge.
- Follow the illustrations.

**Note:** when glass is being removed, which side faces into the oven. Incorrect replacement may cause the glass to shatter or be damaged.

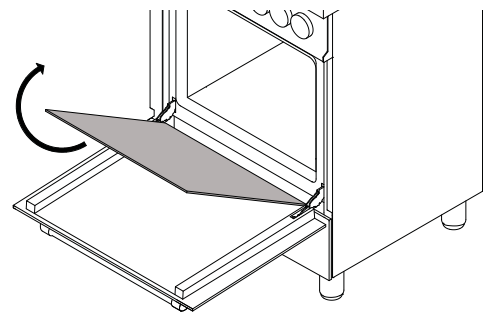
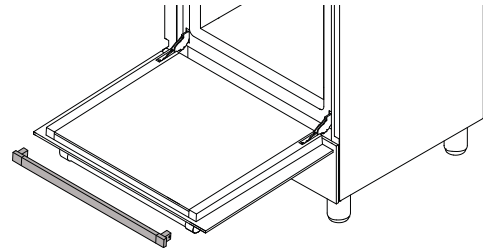
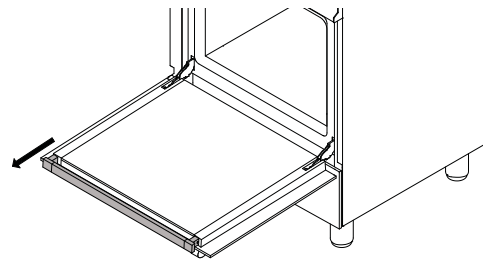
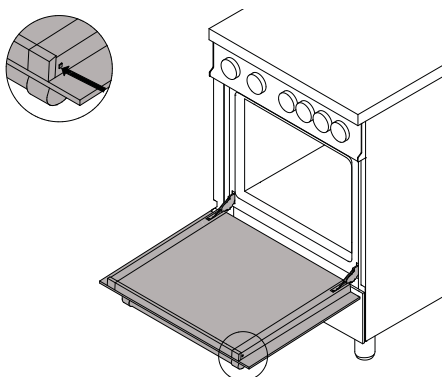
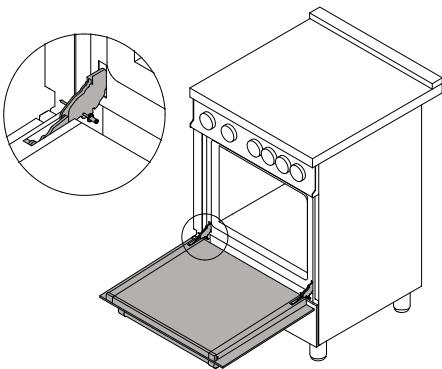
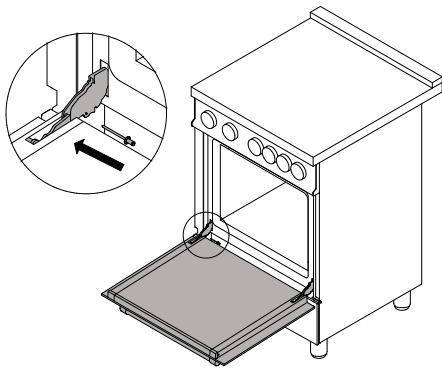

**Warning!**  
If the hinges are not locked properly and the inner glass is removed, the door can close by itself causing personal injuries.

## TROUBLESHOOTING

Here are answer to common problems you may experience. You are also welcome to call our toll free Customer Service line to troubleshoot any issue with your Bertazzoni:

### **ENGLISH 866 905 0010**

if located in the US, BC, B, Sk and MB

### **FRANCAIS 800 561 7265**

if located in ON, QC, PE, NU, NS, NL, NB

### **The oven will not operate**

Is there power to the range? Are the igniters or burner holes blocked? Check the switch fuse or circuit breaker.

### **The surfer burners will not ignite**

Is there power to the range? Are the igniters or burner holes blocked? Are the burner rings and burner caps seated firmly?

Check the switch fuse or circuit breaker. Check that the igniter is clean and the burner holes are open and clean of any residue.

### **The burner ignites but switches off when the knob is released**

The burners have flame failure devices fitted as standard. Therefore, after lighting the burner, keep the knob pressed for a few seconds to deactivate the flame failure device.

### **The ignition candles are sparking continuously**

Is the cooktop wet from cleaning or a boil over? Turn off the electricity supply and thoroughly dry the burner components and igniters.

### **The control knob are getting too hot**

Are you cooking with the oven door open? Keep the oven door shut when not in use or when grilling/broiling.

### **A control knob is loose on its shaft**

The knob retaining spring clip may have been damaged. Call our service department for advice and a replacement if necessary.

### **Food is cooking too quickly**

Are you using a convection mode? When using a fan-assisted oven cooking mode, it is recommended to reduce the cooking tempe-

rature by 70°F (20°C) compared to conventional cooking.

### **Food is not cooking evenly**

Are you cooking large amount of food or are you using large bakeware?

Air needs to circulate through the oven for even cooking. Remove the grill pan from the oven when not in use and always allow a gap on all four sides of dishes. You may need to turn your bakeware during the cooking cycle. Oversized baking sheets, roasting pans and cakeware will act as a baffle and prevent hot air from moving evenly around the cavity. Choose cooking equipment that allows a minimum of 1 inch (2,5 cm) space on all sides to allow the free movement of heat inside the cavity.

### **Grilling in the oven is slow**

Have you selected the correct function?

### **The fan continues to run after the oven is switched off**

This is normal. The cooling fan may run on and off for up to 30 minutes after the oven is switched off to keep the controls cool.

### **Condensation forms in the oven**

Have you pre-heated the oven? Condensation is less likely to form when the oven or grill is pre-heated before use.

### **Smoke is generated in the oven**

Have you selected the right cooking temperature? Are you cooking food with high fat? Do you rarely use the grill? Have you cooked fat under the grill? Does the oven interior need to be cleaned?

Remember to reduce the oven temperature by 70°F (20°C) if using a fan function with a recipe designed for conventional cooking. Use high-sided dishes to contain fats and splashes. Leave the grill on for a few minutes after grilling or roasting to burn off fat deposits from the oven roof. Oven surfaces should be cleaned regularly to prevent build-up of cooking residues.

Please kindly register on our web site [www.bertazzoni.com](http://www.bertazzoni.com) to validate your new product warranty and help us to assist you better in case of any inconvenience.

## TWO YEAR LIMITED WARRANTY

The warranties provided by Bertazzoni SpA in this statement apply exclusively to Bertazzoni appliances and accessories sold as new products to the original owner by a Bertazzoni authorized distributor, retailer, dealer or service center and installed in the United States and Canada. The warranties provided in this statement are not transferable and have validity from the date of installation.

### Coverage information

Bertazzoni SpA will repair or replace any component part which fails or proves defective due to materials and/or workmanship within 2 years from the date of installation and under conditions of normal residential use. Repair or replacement will be free of charge, including labor at standard rates and shipping expenses. Repair service must be performed by a Bertazzoni Authorized Service Center during normal working hours.

### Cosmetic warranty

Bertazzoni will cover parts showing cosmetic defects in material and workmanship for a period of thirty (30) days from date of installation of the unit. This coverage will include scratches, stains, surface imperfections on stainless steel, paint and porcelain, with the exclusion of slight differences in color due to materials and painting/enamelling technologies.

**Exclusions are labor costs, B stock items, out-of-box appliances and display units.**

### How to obtain service

To obtain warranty service please contact Bertazzoni Customer Service at the numbers below and provide model number, serial number and date of purchase.

**ENGLISH 866 905 0010**

if located in the US, BC, B, Sk and MB

**FRANCAIS 800 561 7265**

if located in ON, QC, PE, NU, NS, NL, NB

Save proof of original purchase or of original installation to establish warranty period. Copy of the product serial tag is affixed to the back cover of the instruction manual.

### What is not covered

The product used in any commercial application  
Repair service provided by other than a Bertazzoni authorized service agency.  
Damage or repair service to correct service pro-

vided by an unauthorized agency or the use of unauthorized parts.

Installation not in accordance with local electrical codes, gas codes or plumbing codes

Defects or damage due to improper storage of the product.

Defects or damage or missing parts on products sold out of the original factory packaging or from displays.

Service calls or repairs to correct the installation of the product and/or related accessories.

Service calls to connect, convert or otherwise repair the electrical wiring and/or gas line to properly use the product.

Service calls to provide instructions on the use of a Bertazzoni product.

Repair service due to product usage in manner other than what is normal and customary for home use.

Replacement of wear and tear parts

Replacement of glasses and light bulbs if they are claimed to have failed later than 30 days after installation and in no case later than 4 months after date of purchase

Defects and damages arising from accident, alteration, misuse, abuse, improper installation.

Defects and damages arising from transportation of the product to the home of the owner.

Defects and damage arising from external forces beyond the control of Bertazzoni SpA such as fire, flood, earthquakes and other acts of God.

**In case the product will be installed in a remote area, where certified trained technicians are not reasonably available, the customer will be responsible for the transportation costs for the delivery of the product to the nearest authorized service center or for the displacement costs of a certified trained technician.**

**Bertazzoni does not assume any responsibility for incidental or consequential damages.**

Some states do not allow the exclusion or limitation of incidental or consequential damages, so the above limitation or exclusion may not apply to you. This warranty gives you specific legal rights and you may also have other rights which may vary from state to state or province to province.