



## All Refrigerator

FFRU17B2QW

Frost Free  
16.6 Cu. Ft.



### Product Dimensions

Height (Including Hinges)	67-11/16
Width	34"
Depth (Including Door)	28-1/2"

### More Easy-To-Use Features

Colour-Coordinated Handle

5 Fixed Door Racks

1 Trivet

Available in:



White  
(W)

## Signature Features

### Frost-Free Operation

Never defrost your refrigerator again so you can spend time on more important things.

### Bright Lighting

Our bright lighting makes it easy to see what's inside.

### Ready-Select® Controls

Easily select options with the touch of a button.

### Adjustable Temperature Control

Select the correct temperature for your needs.

Features	
Door Handle Design	UltraSoft™
Reversible Door	
Automatic Door Closer	Yes
Leveling Legs	Yes
Adjustable Temperature Control	Mechanical Dial
Defrost	Frost Free
Temp Display Mode	1 - 7
Full-Width Shelves	3 Adjustable Wire
Slide-Out Wire Baskets	
Interior Lighting	Bright
Door Bins	
Door Racks	5 Full-Width
Fixed Door Shelf Retainers	
Certifications	
CSA Rating	Household
Specifications	
Total Capacity (Cu. Ft.)	16.6
Shelf Area (Sq. Ft.)	18.2
Annual Energy (kWH)	479
Annual Energy Cost (.12/kWH)	\$57
Power Supply Connection Location	Right Bottom Rear
Voltage Rating	115V, 60Hz, 15A
Connected Load (kW rating) @ 115 Volts <sup>1</sup>	0.6
Amps @ 115 Volts	5
Minimum Circuit Required (Amps)	15
Shipping Weight (Approx.)	201 Lbs.

<sup>1</sup>An electrical supply with grounded three-prong receptacle is required. The power supply circuit must be installed in accordance with current local codes & ordinances.

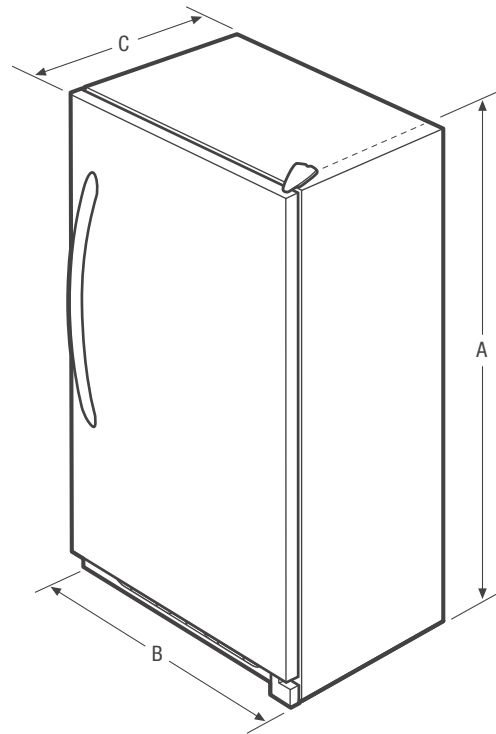

NOTE: For planning purposes only. Always consult local and national electric and plumbing codes. Refer to Product Installation Guide for detailed installation instructions on the web at [frigidaire.ca](http://frigidaire.ca).



Product Dimensions	
A - Height (Including Hinges)	67-11/16"
B - Width	34"
C - Depth (Including Door)	28-1/2"
D - Depth with Door Open 90°	60-1/4"

Accessories information available on the web at [frigidaire.ca](http://frigidaire.ca)