

**1215WC • 15" Wine Captain® Model • 1000 Series**

**FEATURES & BENEFITS**



STAINLESS FRAME



INTEGRATED FRAME



BLACK FRAME

<b>PERFORMANCE</b>	<ul style="list-style-type: none"> <li>• Volume of 2.9 cu ft holds up to 24 wine bottles (750 ml)</li> <li>• Digital Touch Pad Control is conveniently located on upper face of unit</li> <li>• Temperature range: 38°F - 65°F</li> <li>• Passive cooling system</li> <li>• Rubber mounted compressor virtually eliminates vibration</li> </ul>
<b>INTERIOR/EXTERIOR</b>	<ul style="list-style-type: none"> <li>• Black interior is illuminated with LED lighting that automatically turns off when the door is closed, or can be set to stay on for 3 hours</li> <li>• Three-quarter extension black vinyl wine racks with natural beech wood fronts allow for easy access and prevent bottles from shifting</li> <li>• Wine racks accommodate a variety of bottle shapes and sizes, while the fourth and fifth racks allow for larger diameter wine and champagne bottles</li> <li>• LowE coated, argon gas filled, dual thermopane glass door provides protection from harmful UV light</li> <li>• Standard commercial stainless steel handle is interchangeable with professional handle accessory</li> <li>• Door swing is field reversible</li> </ul>
<b>INTEGRATION</b>	<ul style="list-style-type: none"> <li>• Unit is designed to be built-in or can be freestanding</li> <li>• Solid natural beech wood fronts on wine racks can easily be stained to match surrounding cabinetry</li> <li>• Integrated model requires 3/4" custom door panel (panels not supplied by U-Line)</li> <li>• Four independently adjustable leveling legs provide a precise undercounter fit</li> <li>• Available in the following finishes: Stainless, Integrated, or Black</li> </ul>

**MODEL DETAILS**

Model	Voltage/Hz	Door Swing	Finish	Shipping Weight
U-1215WCS-00B	115 / 60	Field Reversible	Stainless Frame	102 lb
U-1215WCINT-00B	115 / 60	Field Reversible	Integrated Frame	99 lb
U-1215WCB-00B	115 / 60	Field Reversible	Black Frame	102 lb

**ACCESSORIES**

Model	Description	Finish	Shipping Weight
80-54247-00	Professional Door Handle, 1 3/4" Diameter	Stainless	2 lb
80-54214-00	Commercial Door Handle, 7/8" Diameter	Stainless	2 lb

**1000 Series • 15" Wine Captain® Model • 1215WC**
**DIMENSIONS**

Dimensions shown apply to all finishes, including Integrated (INT) models with 3/4" integrated panel/frame installed.

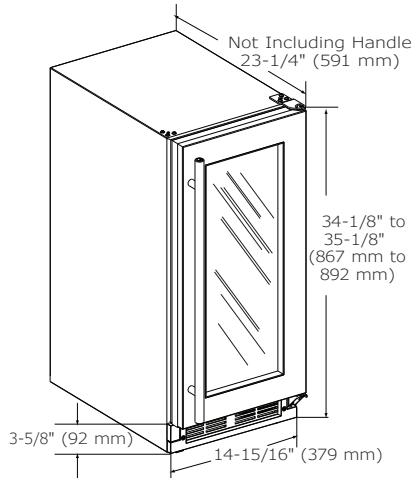
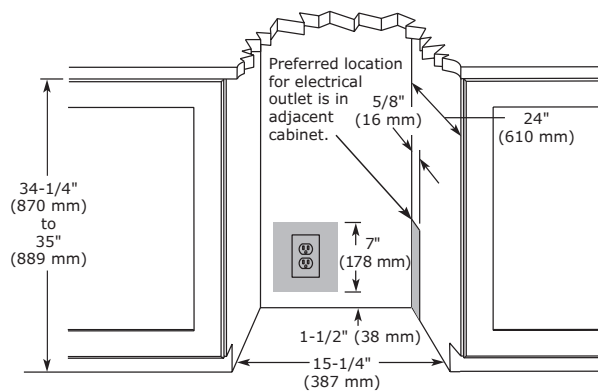
**CABINET CUT-OUT**

**INSTALLATION NOTES**

When installing adjacent to wall, ensure 2 1/2" clearance on hinged side for 90° door opening

Cutout includes the additional 1/4" width overall to ensure proper installation.

No additional clearance around sides, top or rear of unit is needed for ventilation.

Do not obstruct front grille air flow.

**SPECIFICATIONS**

Model	1215WC
Amps: Running	1.2
Capacity: Volume (cu ft)	2.9
Capacity: Wine Bottle (750 ml)	24
Control Type	Digital Touch Pad
Dimensions: Product Depth	23 1/4" / 591 mm
Dimensions: Product Height	34 1/8" / 867 mm
Dimensions: Product Width	14 15/16" / 379 mm
ENERGY STAR	N/A
Panel Height	30 1/4" / 768 mm
Panel Thickness	3/4" / 20 mm
Panel Type	2 3/4" / 70 mm Frame Panel
Panel Width	14 3/4" / 375 mm
Product Weight: Max	95 lb
Refrigerant Type	R600a
Sabbath (Star K Certified)	Yes
Temperature Range	38°F - 65°F

**COOLING SYSTEM**

**ELECTRICAL REQUIREMENTS**

This unit requires a grounded, polarized 115 VAC, 60 Hz, 15 A power supply (normal household current).